

# VANDAL PROOF DOME CAMERA

## DCC-728DV

**680TVL,NR**  
**Sony Effio,3 Axis**

### Features

- SONY 1/3" 480K/570K-Effective Pixel Ex-view HAD CCD II
- High Resolution: More than 680 TV Lines
- NR (Digital Noise Reduction), High Color Reproduction
- High sensitivity and high saturation signal
- Fixed 3.6mm Lens (Optional: 2.8~12mm Lens)

### Picture



### Dimensions

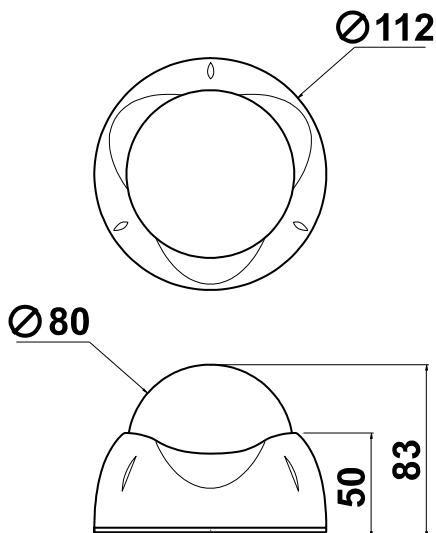

unit : mm

### Specifications

MODEL	DCC-728DV	
Signal system	NTSC	PAL
Image sensor	11/3" Sony 480K/570K Ex-view super HAD CCD II	
Total pixels	1020(H)X508(V)	1020(H)X596(V)
Effective pixels	976(H)X494(V)	976(H)X582(V)
Resolution	680 TVL (B/W 700 TV Lines)	
Scanning frequency	15.734KHz(H), 60(V)	15.625KHz(H), 50(V)
Shutter speed	1/60~1/100,000 sec	1/50~1/100,000 sec
Minimum illumination	Color 0.1Lux(50IRE) @F1.2 B/W 0.08Lux(50IRE)	
Digital Day & Night	Auto	
White balance	ATW	
AGC	Auto	
IP rate	65	
S/N ratio	More than 50dB	
Video output	Composite video output 75Ω terminated	
Lens	3.6mm Fixed Lens	
Sync. system	Internal	
Operating humidity	30 % ~ 90 % RH	
Operating temperature	- 10°C to 50°	
Materials	Aluminum Body (Ivory) PC Bubble	
Dimension	φ80(Bubble) x 83(H)	
Weight	About 600g	
Power consumption	Max 1.8W	
Power supply	DC 12 V(10.2V~14.5 V)	